

# AROMAPACK

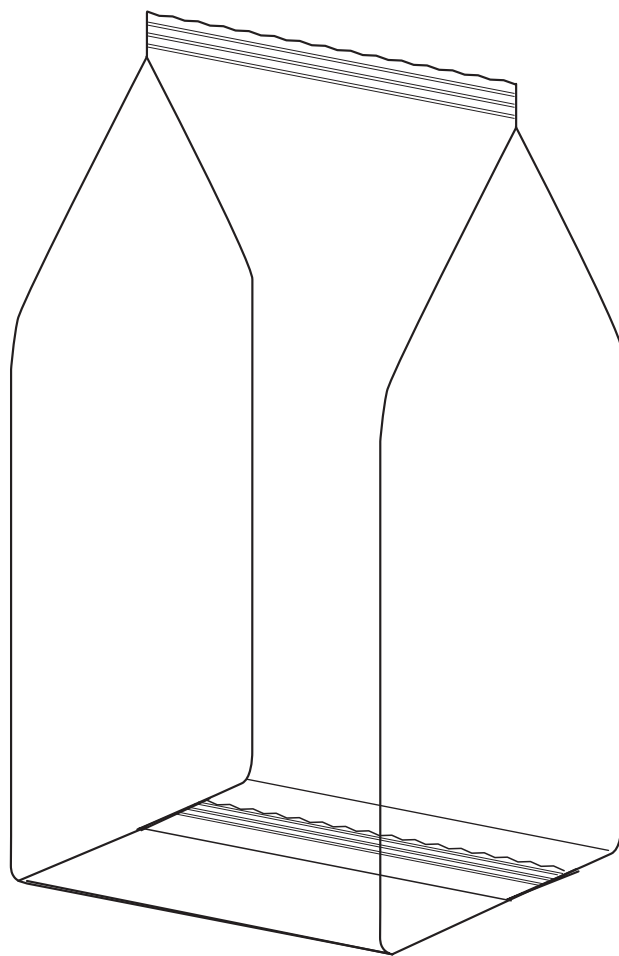

# AROMAPACK 10 STATION

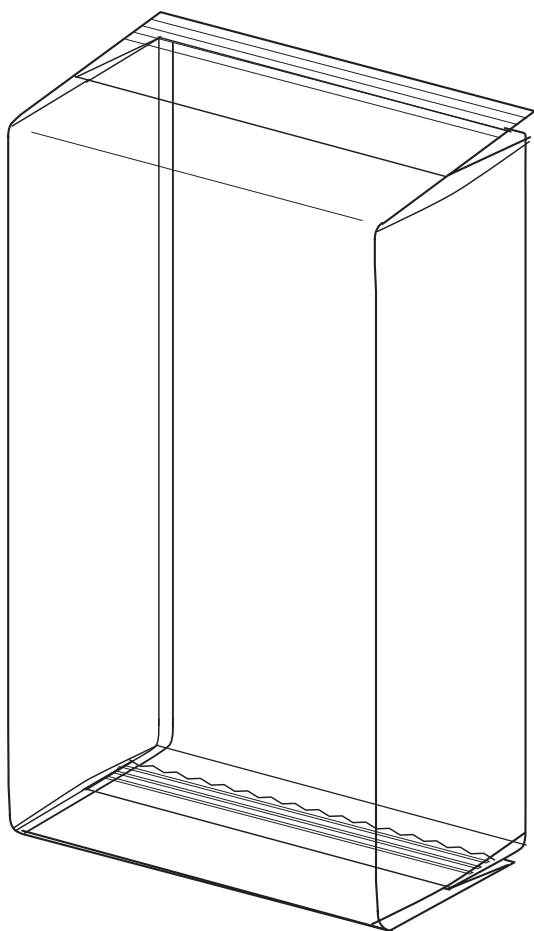
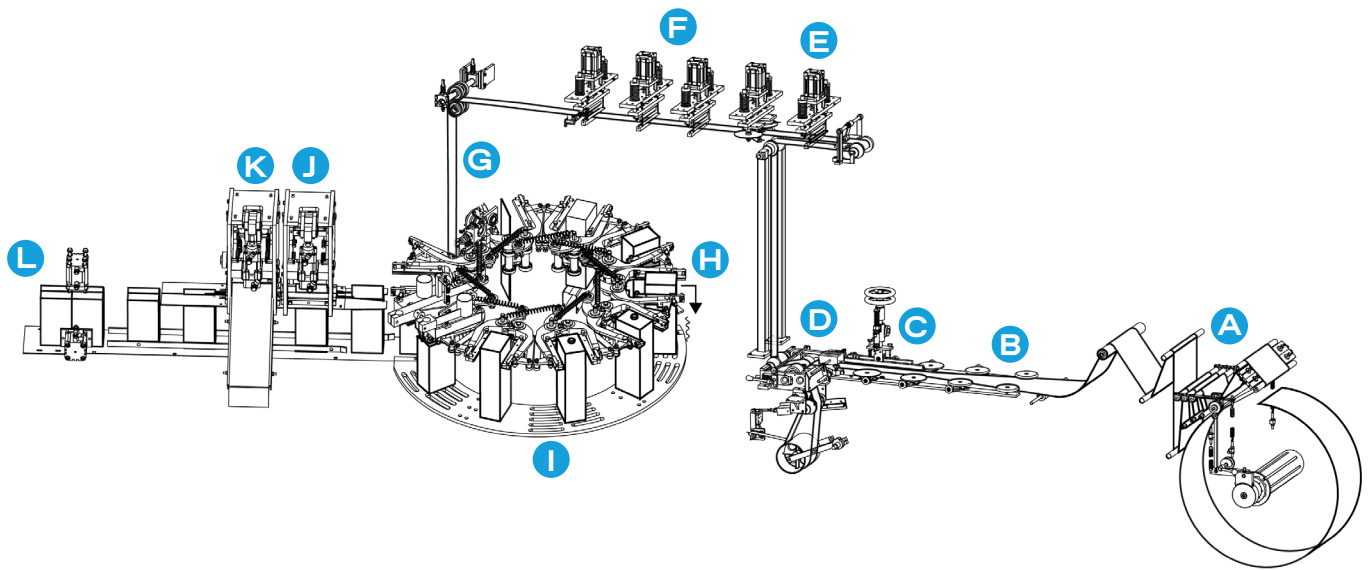

- A. Film unwinding
- B. Tubular forming
- C. Longitudinal sealing
- D. Film pulling device
- E. Corner sealing (optional)
- F. Bottom and K sealing
- G. Bag insertion in the turntable
- H. Product discharge
- I. Product vibration and settling
- J. Top sealing
- K. Trimming and waste recovery
- L. Bags outfeed

**UP TO 50 BAGS/MIN**

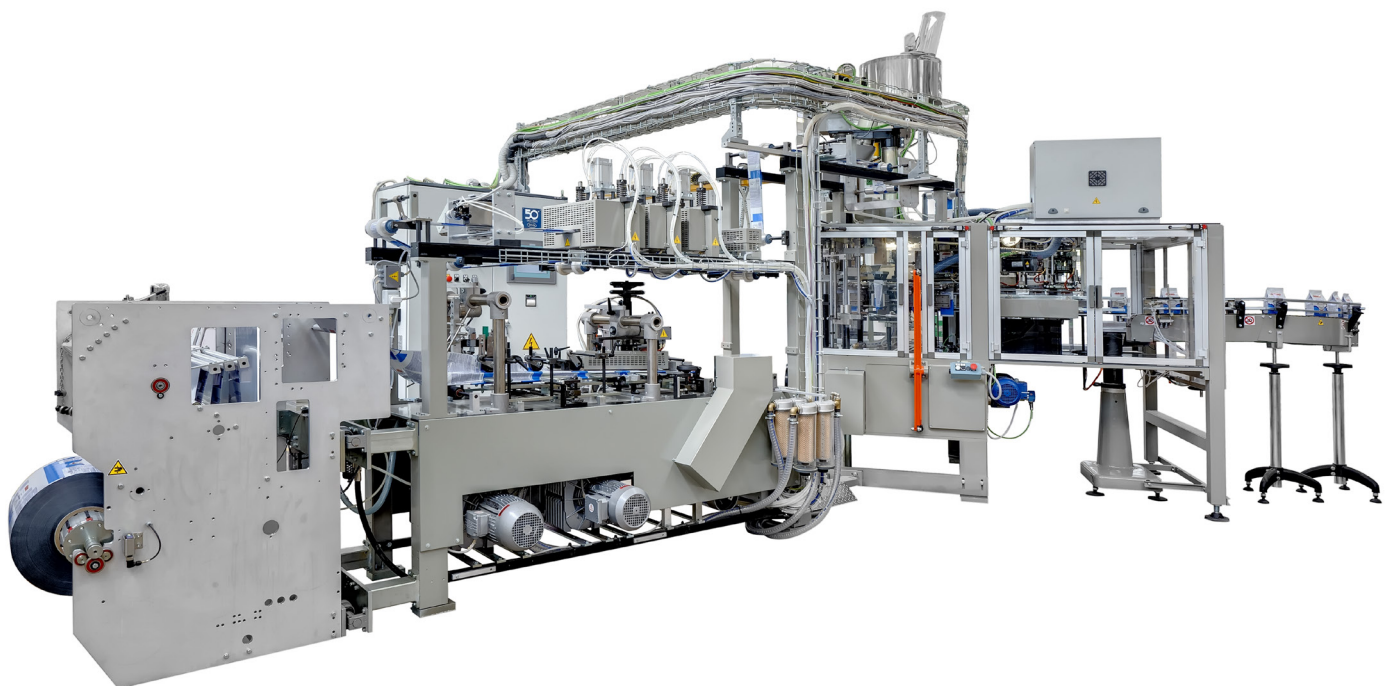

in picture Arompack 10 Station version

# AROMAPACK 60

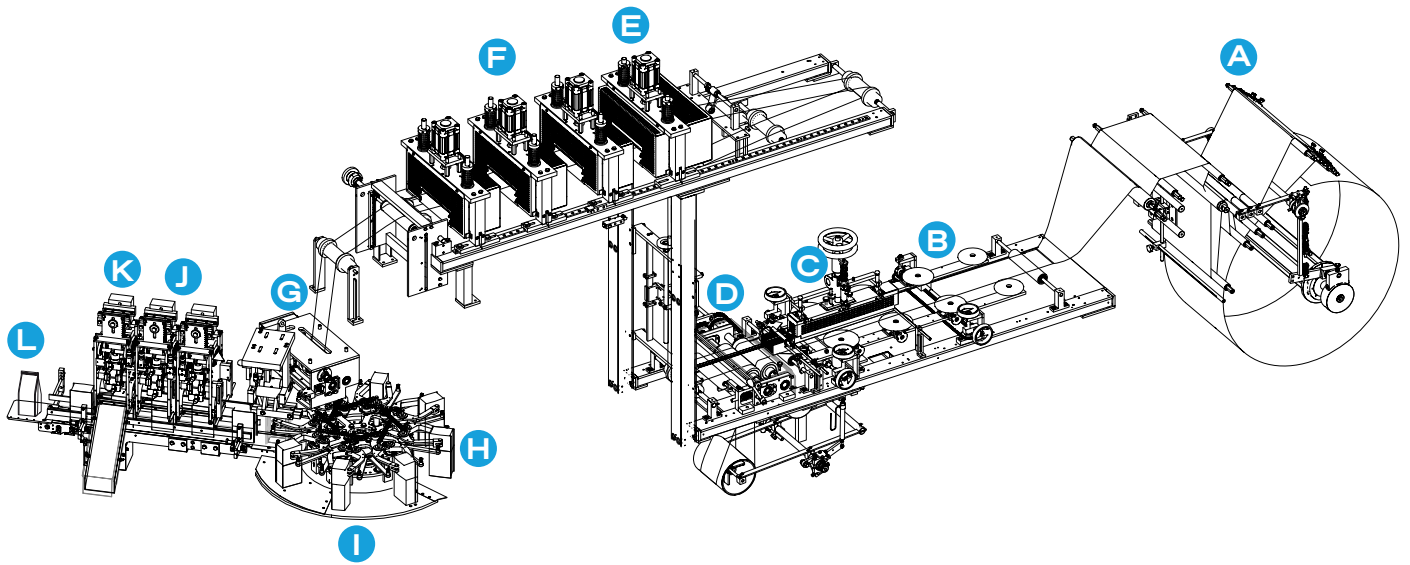

- A. Film unwinding
- B. Tubular forming
- C. Longitudinal sealing
- D. Film-pulling device
- E. Corner sealing (optional)
- F. Bottom and K sealing
- G. Bag insertion in the turntable
- H. Product discharge
- I. Product vibration and settling
- J. Top sealing
- K. Trimming and waste recovery
- L. Bags outfeed

UP TO 60 BAGS/MIN

## OPTIONAL

### KRAFT PAPER

Work with both kraft paper and heat-sealing material from roll stock on the same machine. Bottom blocked by hot melt glue.



### FB DUPLEX

Two bag forming devices permanently installed that allow a quicker size changeover without wasting film.

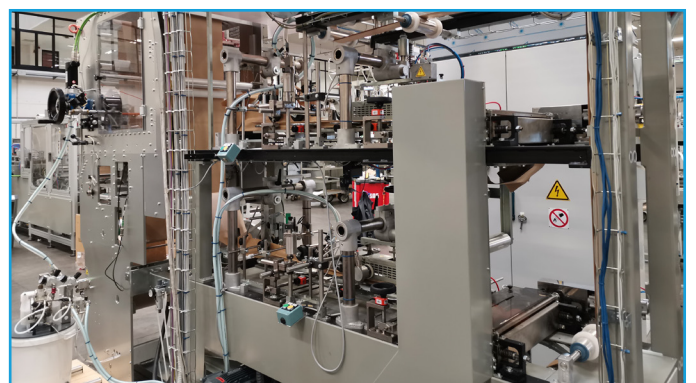

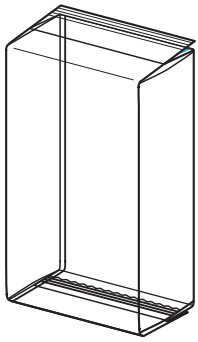

**FLAT TOP**

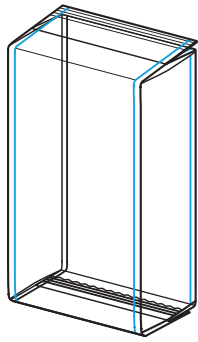

**FLAT TOP  
4 CORNERS  
SEALED**

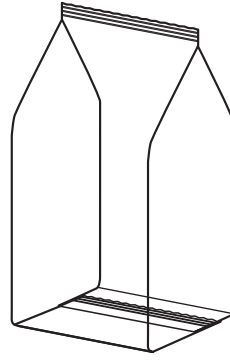

**STANDING  
FIN**

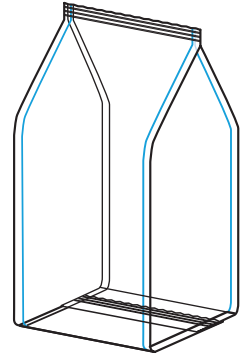

**STANDING  
FIN  
4 CORNERS  
SEALED**

## TOP TREATMENTS

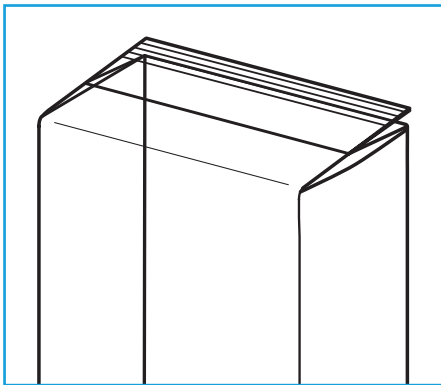

single fold on flat top

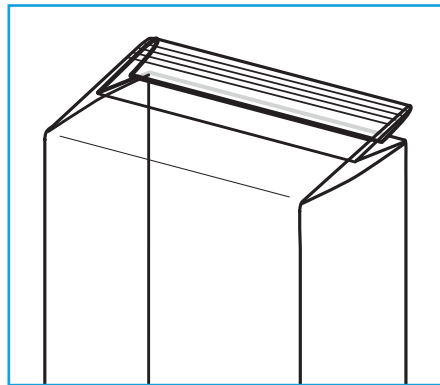

double fold on flat top

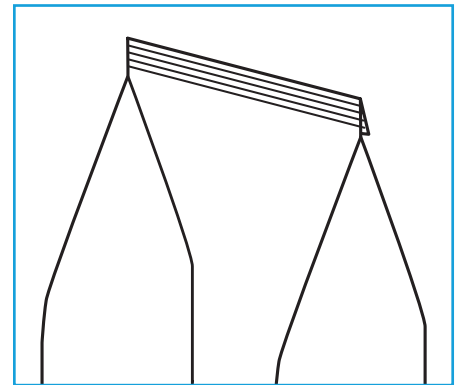

standing fin folded

## TOP FIN FIXING

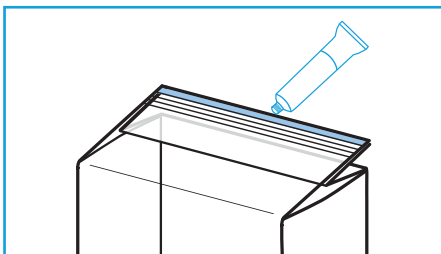

hot melt

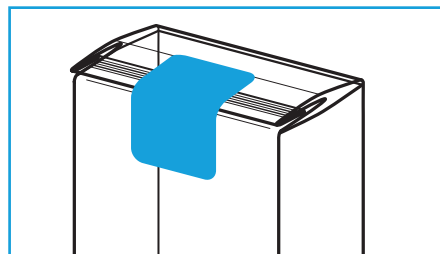

label on flat top  
available also on standing fin  
folded once

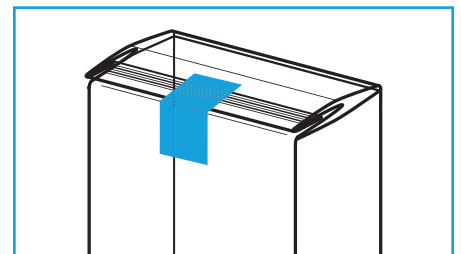

adhesive tape on flat top  
available also on standing fin  
folded once

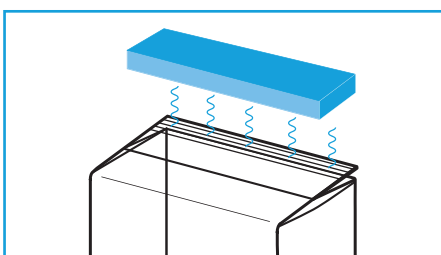

hot-bar flap compression

# OPTIONAL

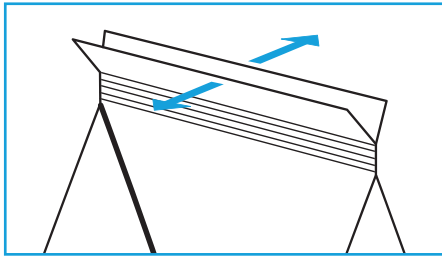

easy opening

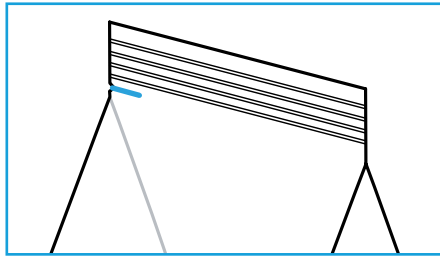

easy opening cut

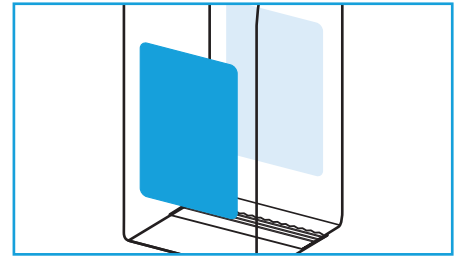

front and/or rear label

# FEEDING SYSTEMS

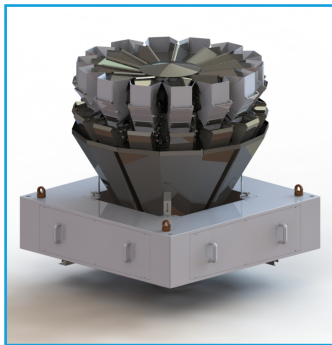

multihead weigher

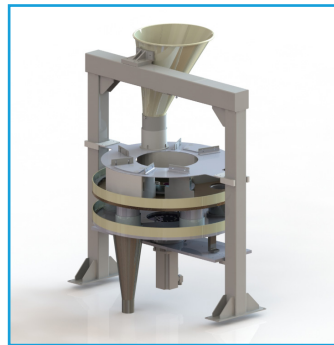

cup filler

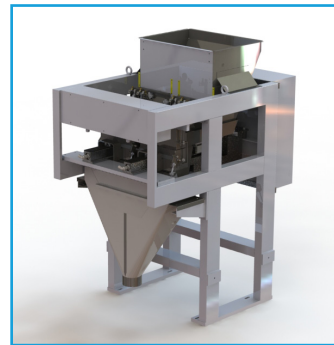

linear weigher

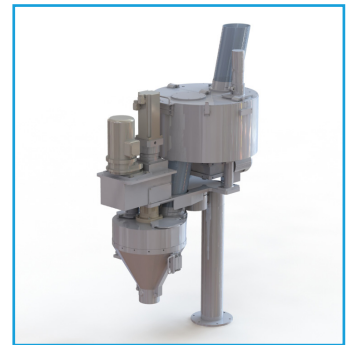

auger filler

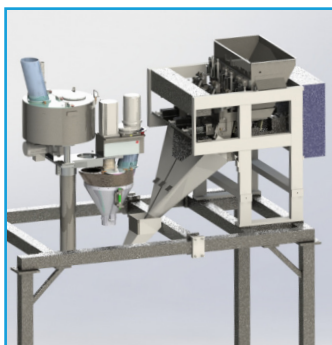

auger filler + linear  
weigher combined



elevator



aspirator



**ICA S.P.A.**  
**Packaging Machines**  
Bologna, Italy • +39 051 6017900 • [com@icaspa.it](mailto:com@icaspa.it) • [www.icaspa.it](http://www.icaspa.it)



**ICA S.P.A.**  
**Packaging Machines**

Bologna, Italy  
+39 051 6017900  
com@icaspa.it  
www.icaspa.it

AROM  
APACK