

CSV40 VERTICAL SERIES

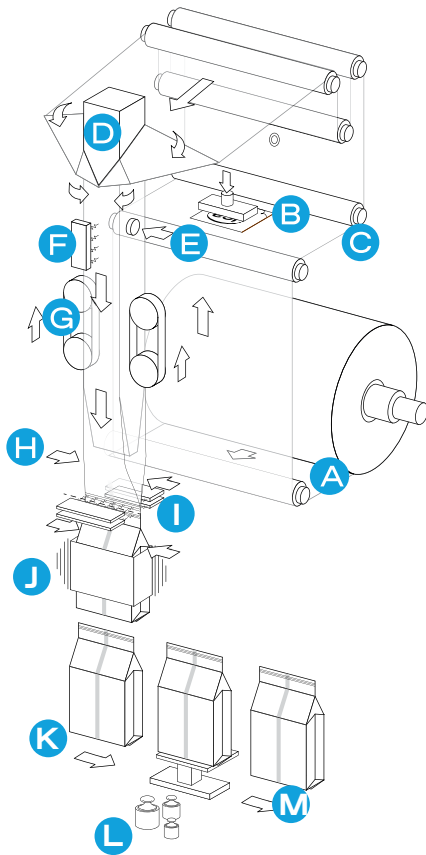

CSV40 N/NTS/MAXI



- A. Film unwinding
- B. Label / valve fitting / printer
- C. Double film pulling
- D. Gas flushing
- E. Cap application
- F. Longitudinal seam-sealed corners
- G. Film pulling-tubular forming
- H. Bottom forming
- I. Bottom sealing and film cutting / tear notch / euroslot
- J. Vibration
- K. Bottom flap fold
- L. Check weigher - metal detector
- M. Bag outfeed

N/NTS: up to 75 bags/min
MAXI: up to 50 bags/min

CSV40 N/NTS
Plant view*

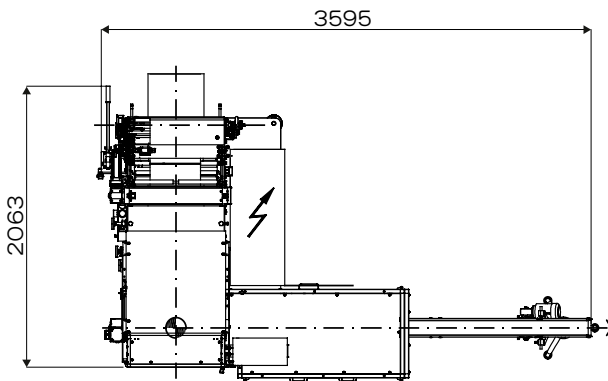

CSV40 N/NTS
Front view*

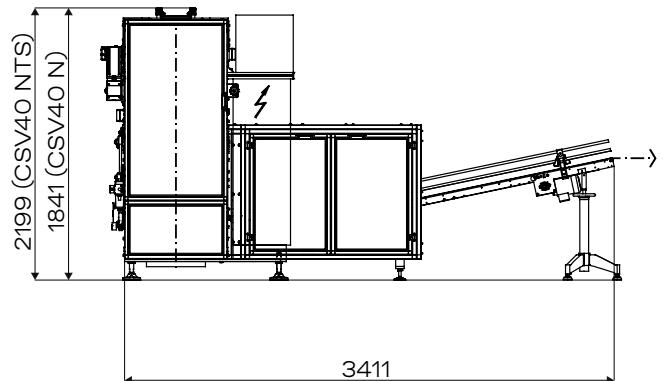

CSV40 MAXI
Plant view*

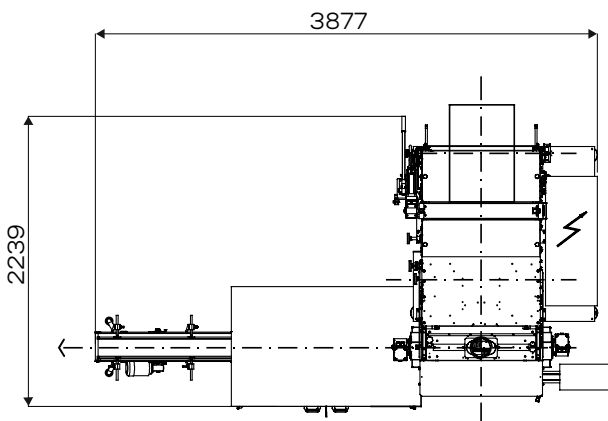

CSV40 MAXI
Front view*

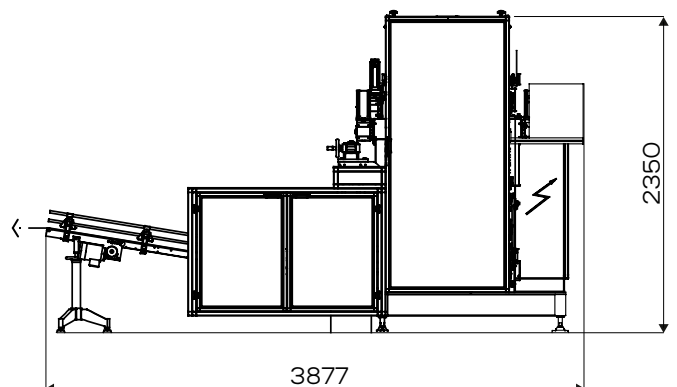

*outfeed configuration can be equally left, right or frontal according with fitting devices

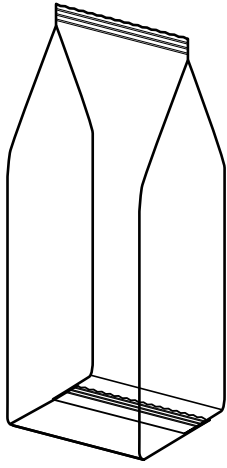

GABLE TOP

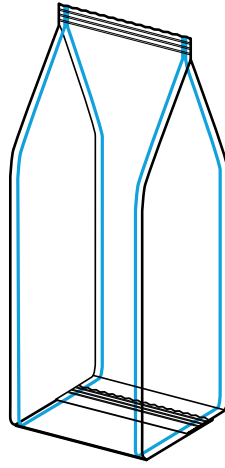

**GABLE TOP
WITH 4 CORNERS
SEALED**

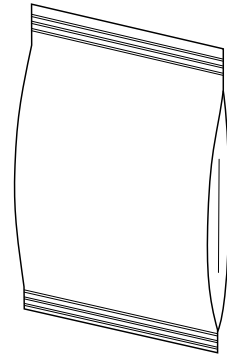

PILLOW PACK

OPTIONAL

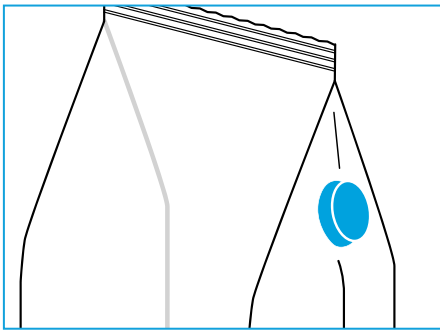

cap application

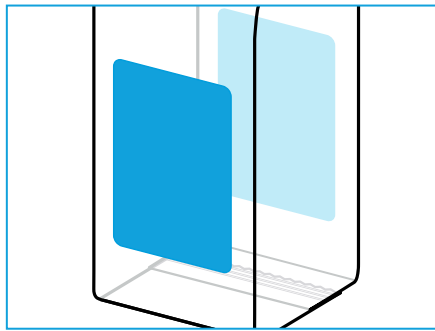

front and/or rear label

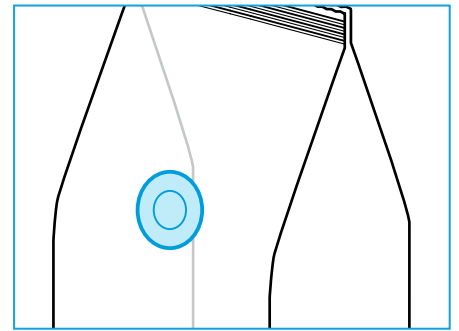

degassing valve

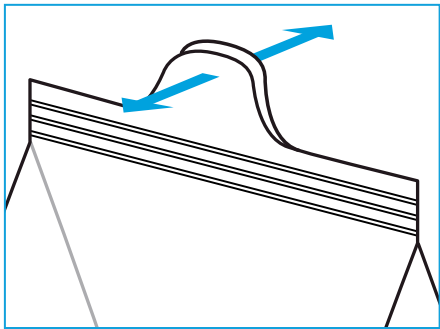

shaped fin

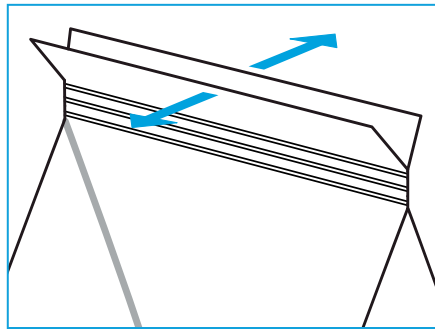

easy opening film

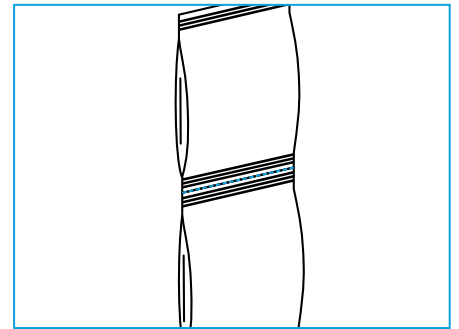

pillow in chain

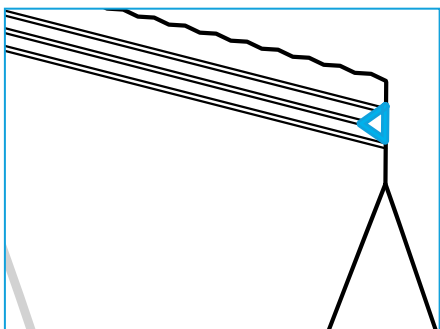

tear notch easy open

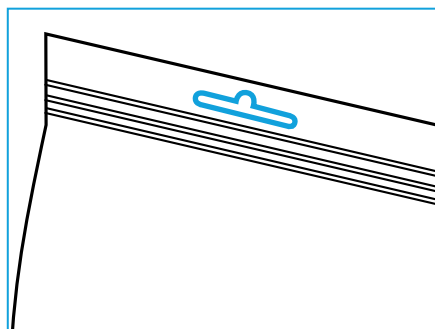

euroslot

FEEDING SYSTEMS

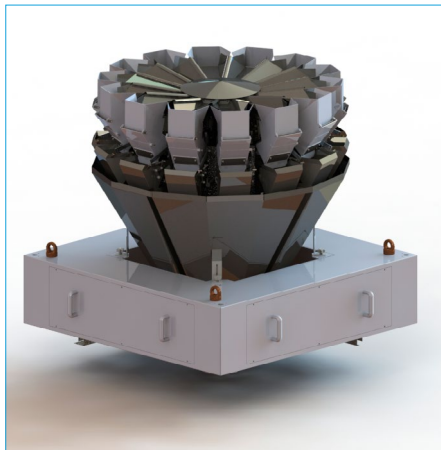

multihead weigher



cup filler

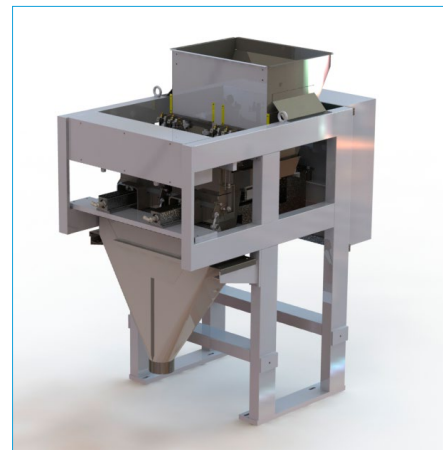

linear weigher

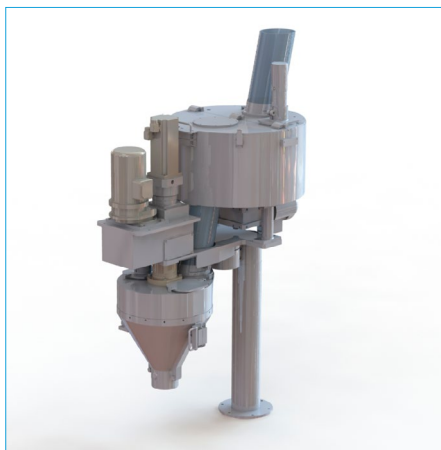

auger filler

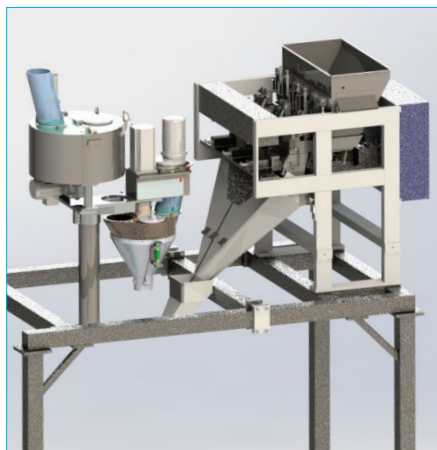

auger filler + linear weigher
combined



elevator



aspirator



ICA S.P.A.
Packaging Machines
Bologna, Italy • +39 051 6017900 • com@icaspa.it • www.icaspa.it

The information contained in this document can be modified without notice. Guarantees for ICA products and services are expressly foreseen in the warranty which accompanies said products or services.
ICA is not responsible for technical or editorial mistakes or omissions contained in the present document.
The technology of the machines shown is protected by international patent.